

- IT RIDUTTORI E MOTORIDUTTORI SEMPLICI
- EN SINGLE GEARBOXES AND GEARED MOTORS
- DE EINZELGETRIEBE UND -GETRIEBEMOTOREN
- FR RÉDUCTEURS ET MOTORÉDUCTEURS SIMPLES
- ES REDUCTORES Y MOTORREDUCTORES SIMPLES
- PT REDUTORES E MOTORREDUTORES SIMPLES

**I 80**

 Albero lento / Output shaft / Abtriebswelle  
 Arbre petite vitesse / Eje lento / Eixo de saída

**D = 35 mm**
**MI 80**

i	n <sub>1</sub>	n <sub>2</sub>	M <sub>2</sub>	kW <sub>1</sub>	HP <sub>1</sub>	RD
7,5	<b>2800</b>	373	166	7,22	9,82	0,90
10		280	148	4,94	6,72	0,88
15		187	215	4,91	6,67	0,86
20		140	196	3,48	4,74	0,83
25		112	187	2,69	3,66	0,82
30		93	243	2,99	4,06	0,80
40		70	224	2,24	3,05	0,73
50		56	190	1,61	2,19	0,69
60		47	187	1,40	1,90	0,65
80		35	182	1,19	1,62	0,56
100	28	161	0,89	1,21	0,53	

i	n <sub>1</sub>	n <sub>2</sub>	M <sub>2</sub>	kW <sub>1</sub>	HP <sub>1</sub>	RD	sf
7,5	<b>2800</b>	373	92	4	5,5	0,90	1,80
10		280	120	4	5,5	0,88	1,24
15		187	175	4	5,5	0,86	1,23
20		140	169	3	4	0,83	1,16
25		112	153	2,2	3	0,82	1,22
30		93	179	2,2	3	0,80	1,36
40		70	150	1,5	2	0,73	1,49
50		56	177	1,5	2	0,69	1,07
60		47	147	1,1	1,5	0,65	1,27
80		35	168	1,1	1,5	0,56	1,08
100	28	136	0,75	1	0,53	1,18	

7,5	<b>1400</b>	186,7	195	4,33	5,89	0,88
10		140	174	2,97	4,03	0,86
15		93,3	253	2,94	4,00	0,84
20		70	231	2,09	2,84	0,81
25		56	220	1,61	2,19	0,8
30		46,7	286	1,79	2,44	0,78
40		35	264	1,34	1,83	0,72
50		28	224	0,97	1,31	0,68
60		23,3	220	0,84	1,14	0,64
80		17,5	214	0,71	0,97	0,55
100	14	189	0,53	0,72	0,52	

7,5	<b>1400</b>	186,7	135	3	4	0,88	1,44
10		140	176	3	4	0,86	0,99
15		93,3	258	3	4	0,84	0,98
20		70	243	2,2	3	0,81	0,95
25		56	205	1,5	2	0,8	1,08
30		46,7	287	1,8	2,5	0,78	1,00
40		35	216	1,1	1,5	0,72	1,22
50		28	174	0,75	1	0,68	1,29
60		23,3	196	0,75	1	0,64	1,12
80		17,5	225	0,75	1	0,55	0,95
100	14	195	0,55	0,75	0,52	0,97	

7,5	<b>900</b>	120	224	3,27	4,44	0,86
10		90	200	2,24	3,04	0,84
15		60	291	2,22	3,02	0,82
20		45	266	1,58	2,14	0,79
25		36	253	1,22	1,65	0,78
30		30	329	1,35	1,84	0,76
40		22,5	304	1,01	1,38	0,71
50		18	258	0,73	0,99	0,67
60		15	253	0,63	0,86	0,63
80		11,3	246	0,54	0,73	0,54
100	9	217	0,40	0,55	0,51	

7,5	<b>900</b>	120	759	11,06	15,04	0,86	1,58
10		90	851	9,52	12,94	0,84	1,11
15		60	943	7,20	9,79	0,82	1,01
20		45	851	4,99	6,79	0,80	1,34
25		36	817	3,98	5,41	0,77	1,26
30		30	1047	4,41	6,00	0,74	1,29
40		22,5	978	3,26	4,44	0,71	1,35
50		18	897	2,40	3,26	0,71	1,03
60		15	897	2,11	2,88	0,67	1,24
80		11,3	771	1,60	2,17	0,57	1,00
100	9	713	1,29	1,76	0,52	1,08	

7,5	<b>500</b>	67	263	2,20	2,99	0,84
10		50	235	1,50	2,05	0,82
15		33	342	1,49	2,03	0,80
20		25	312	1,06	1,44	0,77
25		20	297	0,82	1,11	0,76
30		17	386	0,91	1,24	0,74
40		13	356	0,68	0,93	0,68
50		10	302	0,49	0,67	0,65
60		8	297	0,43	0,58	0,61
80		6	289	0,36	0,49	0,52
100	5	255	0,27	0,37	0,49	

	F1	F2	F3	F4	F5
7,5		90	100		80
10		90	100		80
15		90	100		80
20		90	100		80
25		90			80
30		90			80
40		90			80
50	80	90			
60	80	90			
80	80	90			
100	80	90			

Con boccolla \ With bushing \ mit Buchse  
 Avec bague \ Con manguito \ Com bucha

PAM	⊗	56	63	71	80	90	100	112	132	160	180	200
	B5	9/120	11/140	14/160	19/200	24/200	28/250	28/250	38/300	42/350	48/350	55/400
	B14	9/80	11/90	14/105	19/120	24/140	28/160	28/160				

## MI 80 ÷ 175

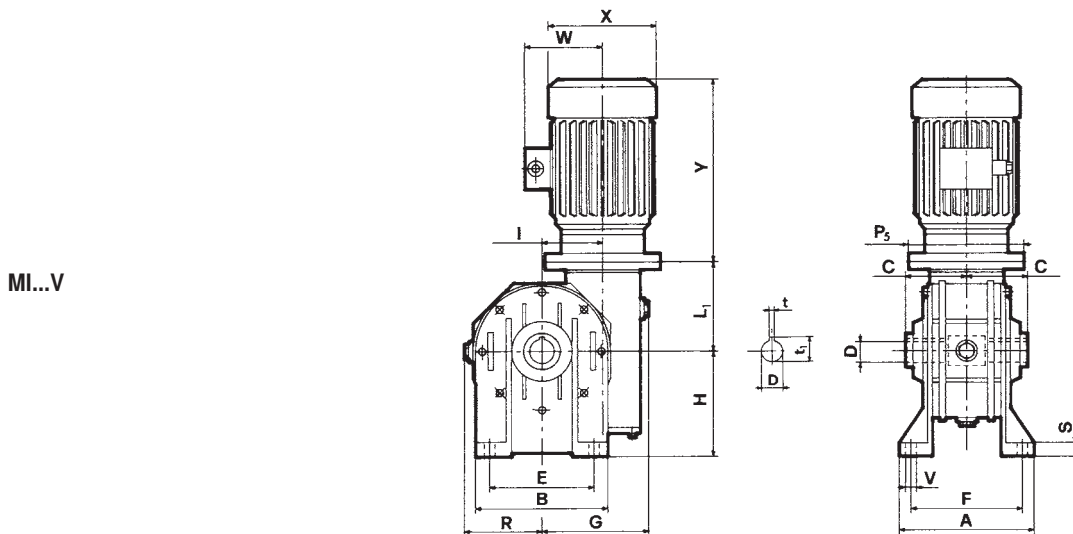
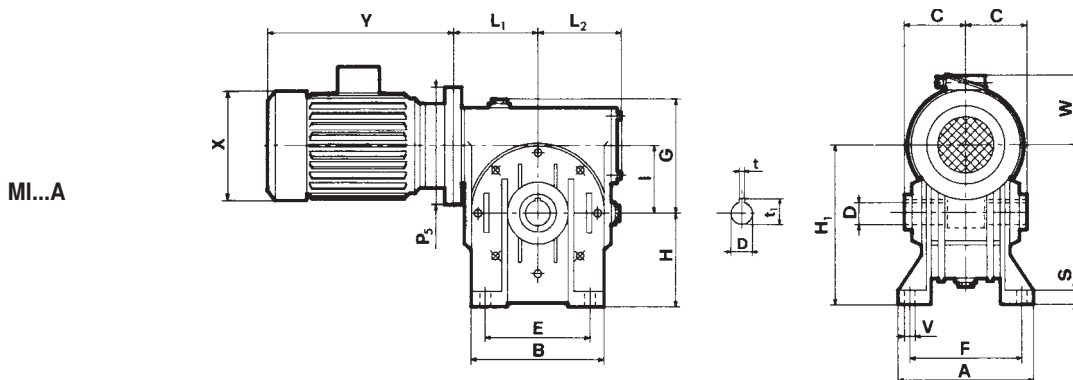
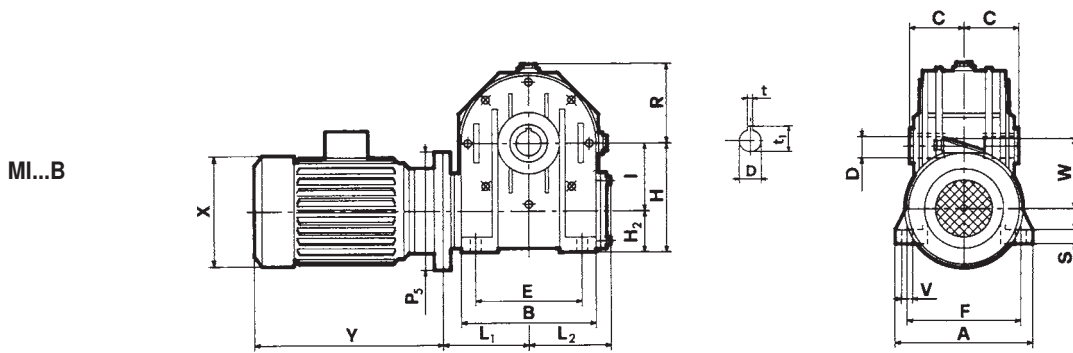

	A	B	E	F	S	V	G	H	H <sub>1</sub>	H <sub>2</sub>	I	L <sub>1</sub>	L <sub>2</sub>	R	C	D H7	t	t <sub>1</sub>
<b>80</b>	181	180	140	147	13	11	127	142	222	62	80	108	105	95	70	35	10	38,3
<b>90</b>	198	210	160	164	15	13	139	150	240	60	90	128	124	111	75	38	10	41,3
<b>110</b>	190	250	200	160	18	13	170	172	282	62	110	149	144	141	77,5	42	12	45,3
<b>130</b>	225	280	240	190	18	15	194	200	330	70	130	165	160	155	95	48	14	51,8
<b>150</b>	260	334	280	220	20	19	225	230	380	80	150	192	190	182	110	55	16	60,3
<b>175</b>	280	358	310	240	30	19	258	260	435	85	175	213	204	203	115	60	18	64,4

P<sub>5</sub>, X, Y, W Vedi tabelle motori in B5 / See motors table B5 / siehe Motorentabellen in B5 / Voir tableaux moteurs en B5 / Ver tablas de motores en B5 / Ver tabelas motores em B5

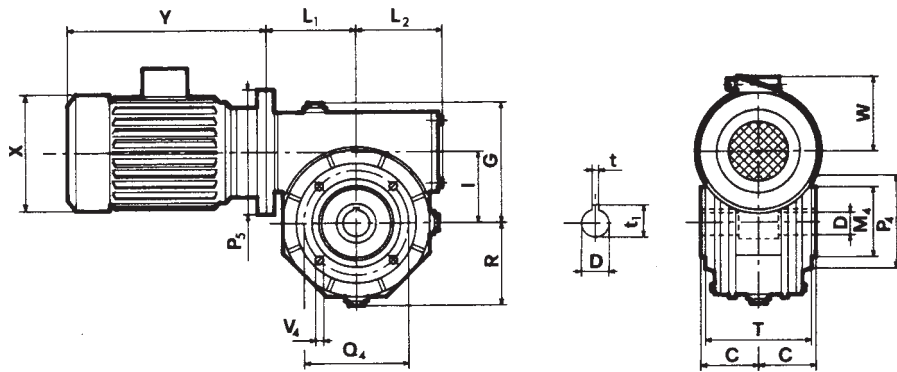
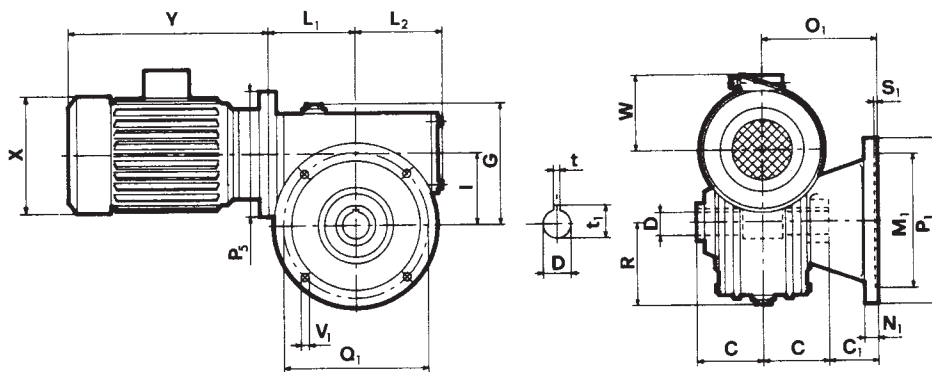
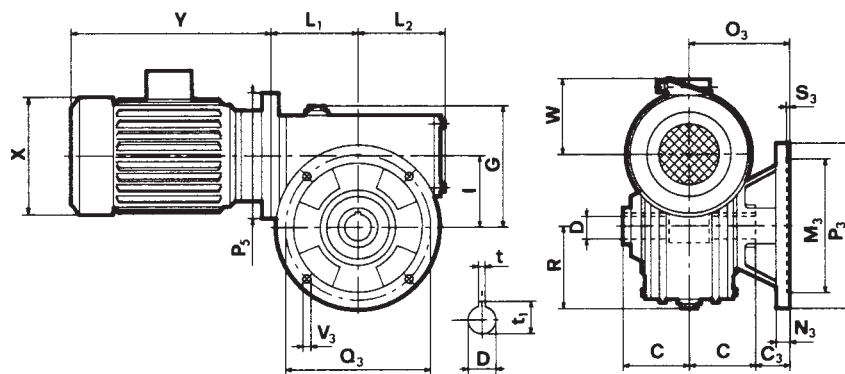
**MI...FP**

**MI...F**

**MI...FBR**

	C <sub>1</sub>	C <sub>3</sub>	M <sub>1</sub> G6	M <sub>3</sub> G6	M <sub>4</sub> G6	N <sub>1</sub>	N <sub>3</sub>	O <sub>1</sub>	O <sub>3</sub>	P <sub>1</sub>	P <sub>3</sub>	P <sub>4</sub>	Q <sub>1</sub>	Q <sub>3</sub>	Q <sub>4</sub>	S <sub>1</sub>	S <sub>3</sub>	V <sub>1</sub>	V <sub>3</sub>	V <sub>4</sub>	G	I	L <sub>1</sub>	L <sub>2</sub>	R	T	C	D H7	t	t <sub>1</sub>
<b>80</b>	50	30	130	110	110	13	13	120	100	200	160	145	165	130	130	5	5	11,5	11,5	M10	127	80	108	105	95	133	70	35	10	38,3
<b>90</b>	52	40	180	130	110	14	15	127	115	250	200	160	215	165	130	5	5	14	11	M10	139	90	128	124	111	143	75	38	10	41,3
<b>110</b>	72,5	52,5	180	180	130	18	18	150	130	250	250	200	215	215	165	5	5	15	15	M12	170	110	149	144	141	148	77,5	42	12	45,5
<b>130</b>	55	42,5	230	230	180	18	18	150	137,5	300	300	240	265	265	215	5	5	15	15	M12	194	130	165	160	155	172	95	48	14	51,8
<b>150</b>	65	-	250	-	180	20	-	175	-	350	-	250	300	-	215	6	-	17	-	M14	225	150	192	190	182	204	110	55	16	60,3
<b>175</b>	95	-	300	-	230	22	-	210	-	400	-	300	350	-	265	6	-	18	-	M16	258	175	213	204	203	224	115	60	18	64,4

P<sub>5</sub>, X, Y, W Vedi tabelle motori in B5 / See motors table B5 / siehe Motorentabellen in B5 / Voir tableaux moteurs en B5 / Ver tablas de motores en B5 / Ver tabelas motores em B5



SOCIETÀ ITALIANA TRASMISSIONI INDUSTRIALI



<b>RIDUTTORI</b>	<i>GEARBOXES</i>
<b>MOTORIDUTTORI</b>	<i>GEARED MOTORS</i>
<b>VARIATORI CONTINUI</b>	<i>SPEED VARIATORS</i>
<b>MOTORI ELETTRICI C.A./C.C.</b>	<i>A.C./D.C. ELECTRIC MOTORS</i>
<b>GIUNTI ELASTICI</b>	<i>FLEXIBLE COUPLINGS</i>

**ITALIA ITALY**

**SEDE e STABILIMENTO HEADQUARTERS**

Via G. Di Vittorio, 4 - 40050 Monteveglio - BO - Italy

Tel. +39/051/6714811 - Fax. +39/051/6714858

E-mail: [info@sitiriduttori.it](mailto:info@sitiriduttori.it)  
[commitalia@sitiriduttori.it](mailto:commitalia@sitiriduttori.it)  
[export@sitiriduttori.it](mailto:export@sitiriduttori.it)

WebSite: [www.sitiriduttori.it](http://www.sitiriduttori.it)



**CINA CHINA**

**Shanghai SITI Power Transmission Co., Ltd.**

Block A, No.558 Xuan Qiu Rd. Sanzao Industrial Park,  
Pudong New Area, Shanghai, P.R.China P.C.:201300

Tel:+86-21-68060500 - Fax:+86-21-68122539

E-mail: [info@sh-siti.com](mailto:info@sh-siti.com)

WebSite: [www.sh-siti.com](http://www.sh-siti.com)

**POLONIA POLAND**

**SITI-TECH Sp. z o.o.**

Milejowice, ul. Napędowa 4

26-652 Zakrzew POLAND

E-mail: [sititech@sititech.pl](mailto:sititech@sititech.pl)

WebSite: [www.sititech.pl](http://www.sititech.pl)

**ROMANIA ROMANIA**

**S.C. SITI BALKANIA SRL**

Piatra Craiului, 7 (Zona Ind. La Dibo) - Hala4 Comp.7 - Jud Prahova - Romania

Tel. +40-244434243 - Fax. +40-244434243

E-mail: [office@sitibalkania.ro](mailto:office@sitibalkania.ro)

WebSite: [www.sitibalkania.ro](http://www.sitibalkania.ro)