

SITI

SPA

SOCIETÀ ITALIANA TRASMISSIONI INDUSTRIALI



U-MU

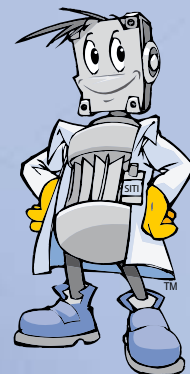

- IT RIDUTTORI E MOTORIDUTTORI SEMPLICI
- EN SINGLE GEARBOXES AND GEARED MOTORS
- DE EINZELGETRIEBE UND -GETRIEBEMOTOREN
- FR RÉDUCTEURS ET MOTORÉDUCTEURS SIMPLES
- ES REDUCTORES Y MOTORREDUCTORES SIMPLES
- PT REDUTORES E MOTORREDUTORES SIMPLES

02.2012

U 90	Albero lento / Output shaft / Abtriebswelle Arbres petite vitesse / Eje lento / Eixo de saída	D = 35 mm	MU 90
-------------	--	------------------	--------------

i	n ₁	n ₂	M ₂	kW ₁	HP ₁	RD	i	n ₁	n ₂	M ₂	kW ₁	HP ₁	RD	sf
7,5	2800	373	267	11,39	15,49	0,918	7,5	2800	373	129	5,5	7,50	0,918	2,07
10		280	270	8,73	11,88	0,908	10		280	170	5,5	7,50	0,908	1,59
15		187	276	6,24	8,49	0,864	15		187	243	5,5	7,50	0,864	1,13
20		140	330	5,64	7,68	0,856	20		140	321	5,5	7,50	0,856	1,03
25		112	288	3,96	5,39	0,853	25		112	291	4	5,50	0,853	0,99
30		93	376	4,47	6,08	0,822	30		93	336	4	5,50	0,822	1,12
40		70	349	3,27	4,45	0,783	40		70	320	3	4,00	0,783	1,09
50		56	306	2,35	3,20	0,763	50		56	286	2,2	3,00	0,763	1,07
60		47	291	1,97	2,68	0,721	60		47	325	2,2	3,00	0,721	0,90
70		40	276	1,66	2,26	0,695	70		40	249	1,5	2,00	0,695	1,11
80		35	254	1,34	1,83	0,694	80		35	284	1,5	2,00	0,694	0,87
100	28	213	0,96	1,31	0,651	100	28	244	1,1	1,50	0,651	0,87		

7,5	1400	187	370	7,97	10,84	0,908	7,5	1400	187	255	5,5 ⁽¹⁾	7,50	0,908	1,45
10		140	369	6,06	8,25	0,893	10		140	335	5,5 ⁽¹⁾	7,50	0,893	1,10
15		93	374	4,23	5,75	0,864	15		93	354	4	5,50	0,864	1,06
20		70	427	3,70	5,03	0,847	20		70	347	3	4,00	0,847	1,23
25		56	373	2,65	3,60	0,826	25		56	310	2,2	3,00	0,826	1,20
30		47	487	3,03	4,12	0,786	30		47	483	3	4,00	0,786	1,01
40		35	457	2,23	3,03	0,752	40		35	451	2,2	3,00	0,752	1,01
50		28	390	1,58	2,14	0,725	50		28	371	1,5	2,00	0,725	1,05
60		23	367	1,30	1,77	0,690	60		23	311	1,1	1,50	0,690	1,18
70		20	348	1,14	1,55	0,639	70		20	336	1,1	1,50	0,639	1,04
80		18	319	0,93	1,26	0,632	80		18	317	0,92	1,25	0,632	1,01
100	14	289	0,71	0,97	0,596	100	14	305	0,75	1,00	0,596	0,95		

7,5	900	120	410	5,76	7,83	0,896	7,5	900	120	157	2,2	3,00	0,896	2,62
10		90	405	4,35	5,92	0,878	10		90	205	2,2	3,00	0,878	1,98
15		60	420	3,13	4,26	0,842	15		60	295	2,2	3,00	0,842	1,42
20		45	450	2,61	3,55	0,813	20		45	380	2,2	3,00	0,813	1,19
25		36	354	1,69	2,30	0,791	25		36	378	1,8	2,50	0,791	0,94
30		30	520	2,17	2,95	0,753	30		30	527	2,2	3,00	0,753	0,99
40		23	490	1,62	2,21	0,713	40		23	454	1,5	2,00	0,713	1,08
50		18	425	1,17	1,60	0,683	50		18	399	1,1	1,50	0,683	1,07
60		15	395	0,97	1,32	0,642	60		15	307	0,75	1,00	0,642	1,29
70		13	369	0,84	1,14	0,593	70		13	330	0,75	1,00	0,593	1,12
80		11	340	0,68	0,92	0,592	80		11	377	0,75	1,00	0,592	0,90
100	9	305	0,53	0,72	0,545	100	9	318	0,55	0,75	0,545	0,96		

7,5	500	67	470	3,87	5,26	0,848		F1	F2	F3	F4	Con boccia \ With bushing \ mit Buchse Avec bague \ Con manguito \ Com bucha	F5
10		50	456	2,91	3,96	0,821	7,5		90	100	112		⁽²⁾ 80
15		33	490	2,19	2,98	0,782	10		90	100	112		⁽²⁾ 80
20		25	520	1,76	2,40	0,771	15		90	100	112		⁽²⁾ 80
25		20	451	1,28	1,74	0,739	20		90	100	112		⁽²⁾ 80
30		17	588	1,45	1,97	0,709	25		90	100	112		⁽²⁾ 80
40		13	542	1,08	1,47	0,656	30		90	100	112		⁽²⁾ 80
50		10	458	0,79	1,07	0,610	40		90	100			⁽²⁾ 80
60		8	427	0,65	0,89	0,570	50		90				⁽²⁾ 80
70		7	402	0,56	0,76	0,538	60		90				
80		6	367	0,48	0,65	0,503	70	80	90				
100	5	355	0,41	0,56	0,451	80	80	90					

⁽¹⁾ Motore Gr. 112 MC (grandezza non unificata) \ Motor Gr. 112 MC (non-standard size) \ Motor Gr.112 (nicht vereinheitlichte Größe) \ Moteur Gr. 112 MC (taille non unifiée) \ Motor Gr. 112 MC (tamaño no unificado) \ Motor Gr. 112 MC (tamanho não unificado).

^(*) Montaggio con boccia fornibile su richiesta a carico del cliente. / Assembling with reduction bushing on request (at customer's charge). / Auf Wunsch des Kunden auch mit eingebauter Buchse lieferbar (zu Lasten des Kunden). / Montage avec douille, disponible sur demande, à la charge du client. / Montaje con manguito bajo pedido a cargo del cliente. / Montagem com bucha a pedido por conta do cliente.

Dove non specificata, la forma costruttiva del motore é fornibile sia in B5 che in B14. / The motors can be supplied either B5 or B14, unless otherwise specified. / Wenn nicht näher spezifiziert, kann die Bauform des Motors sowohl B5 oder B14 entsprechen. / Sauf spécification contraire, le moteur est fourni tant dans la forme de construction B5 que B14. / Las formas constructivas del motor que se suministran son B5 y B14 si no se especifica de otro modo. / Quando não especificada, a forma de construção do motor é fornecida tanto B5 como B14.

U 90

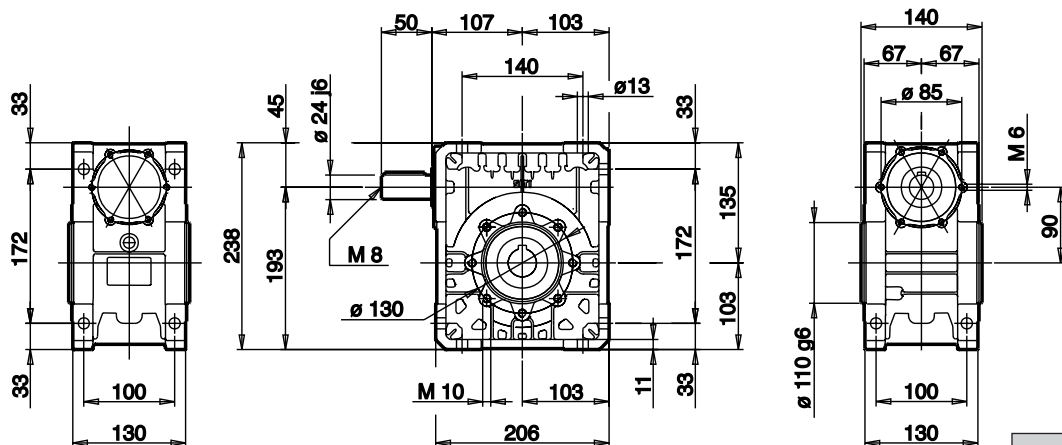

MU 90

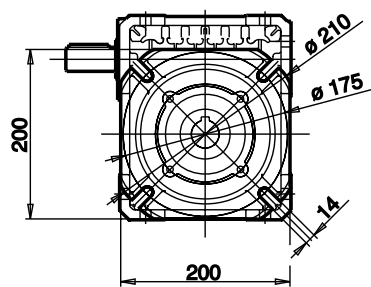
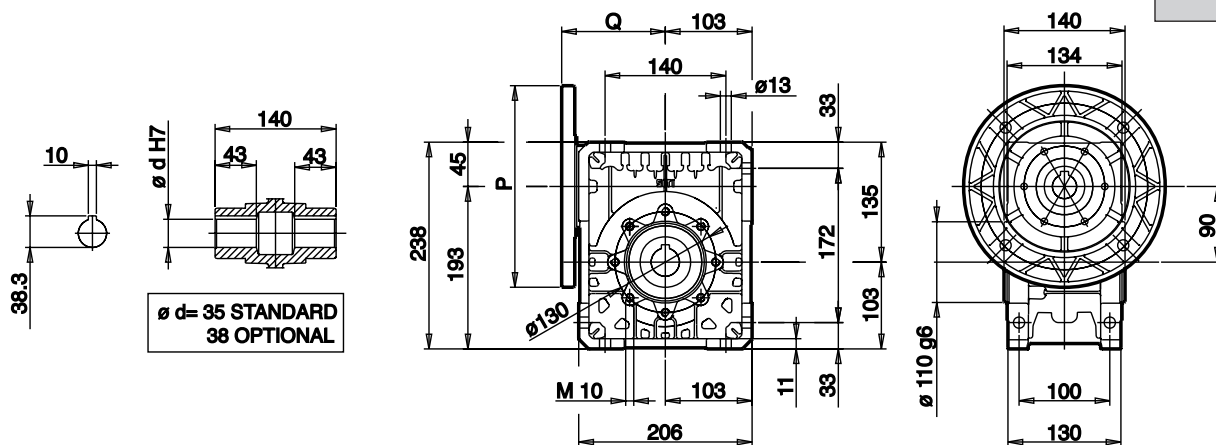

FBM

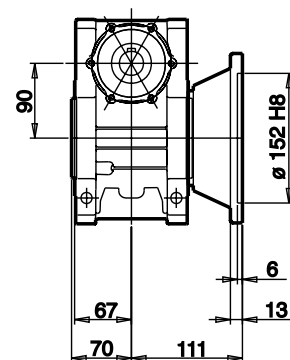

Per i valori **P** e **Q** consultare la tabella a pag. R.4. / Concerning values **P** and **Q** see table page R.4. / Für die Werte **P** und **Q** siehe die Tabelle auf Seite R.4. / Pour des valeurs **P** et **Q**, consulter le tableau page R.4. / Para los valores **P** y **Q**, consulte la tabla de la pág. R.4. / Para os valores **P** e **Q** consulte a tabela na pág. R.4.



SOCIETÀ ITALIANA TRASMISSIONI INDUSTRIALI



RIDUTTORI	<i>GEARBOXES</i>
MOTORIDUTTORI	<i>GEARED MOTORS</i>
VARIATORI CONTINUI	<i>SPEED VARIATORS</i>
MOTORI ELETTRICI C.A./C.C.	<i>A.C./D.C. ELECTRIC MOTORS</i>
GIUNTI ELASTICI	<i>FLEXIBLE COUPLINGS</i>

ITALIA ITALY

SEDE e STABILIMENTO HEADQUARTERS

Via G. Di Vittorio, 4 - 40050 Monteveglio - BO - Italy

Tel. +39/051/6714811 - Fax. +39/051/6714858

E-mail: info@sitiriduttori.it
commitalia@sitiriduttori.it
export@sitiriduttori.it

WebSite: www.sitiriduttori.it



CINA CHINA

Shanghai SITI Power Transmission Co., Ltd.

Block A, No.558 Xuan Qiu Rd. Sanzao Industrial Park,
Pudong New Area, Shanghai, P.R.China P.C.:201300

Tel:+86-21-68060500 - Fax:+86-21-68122539

E-mail: info@sh-siti.com

WebSite: www.sh-siti.com

POLONIA POLAND

SITI-TECH Sp. z o.o.

Milejowice, ul. Napędowa 4

26-652 Zakrzew POLAND

E-mail: sititech@sititech.pl

WebSite: www.sititech.pl

ROMANIA ROMANIA

S.C. SITI BALKANIA SRL

Piatra Craiului, 7 (Zona Ind. La Dibo) - Hala4 Comp.7 - Jud Prahova - Romania

Tel. +40-244434243 - Fax. +40-244434243

E-mail: office@sitibalkania.ro

WebSite: www.sitibalkania.ro